

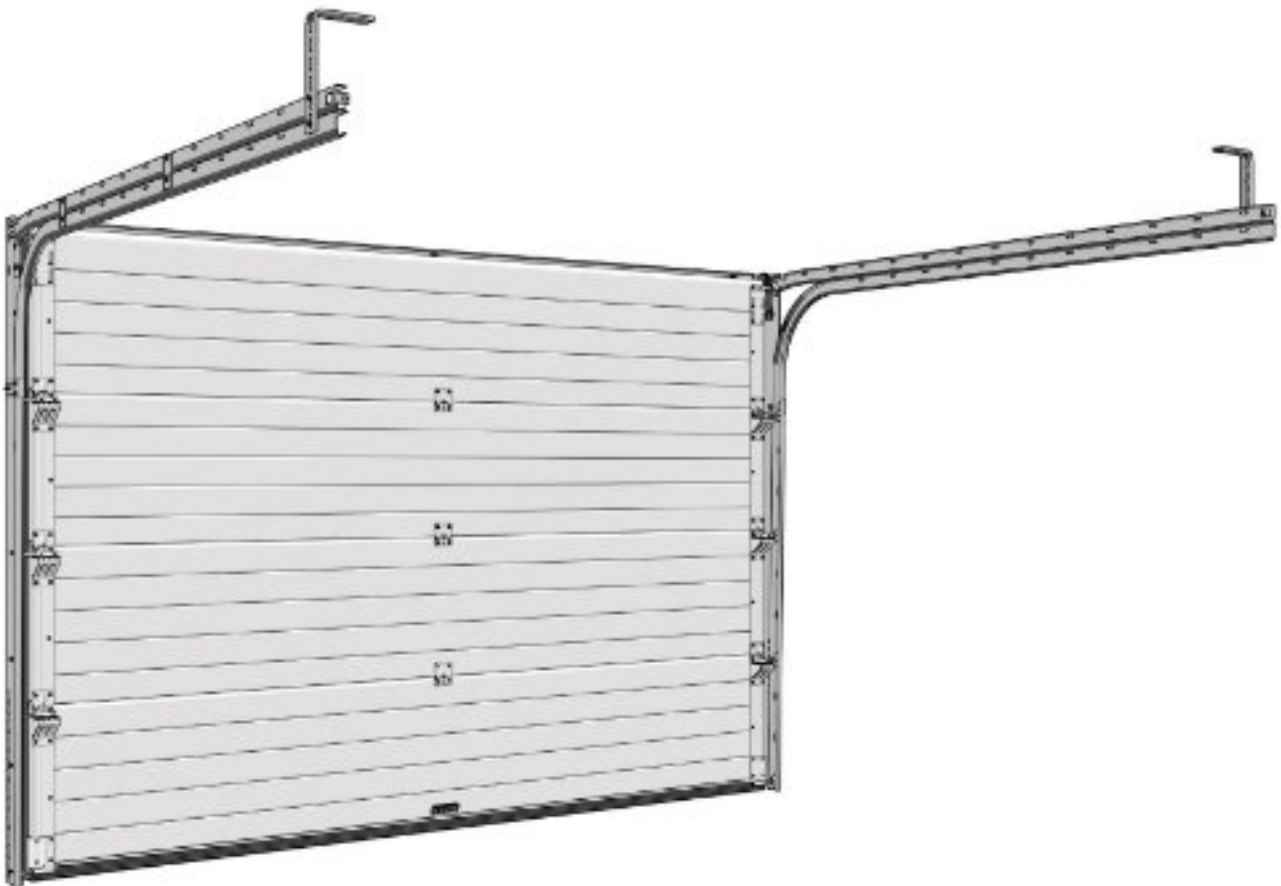

Labona.pl
Zmierz i zainstaluj

INSTRUKCJA MONTAŻU: BRAMA GARAŻOWA SEGMENTOWA



Ogólne zasady

Wy trzymacie w rękach instrukcje montażową bram RSD01 Hybrid DIY. Dana instrukcja zawiera także informacje montażową z wykorzystaniem aluminiowych kształowników.

Instrukcja zawiera ważną informację montażową dla bezpiecznej eksploatacji i obsłudze bramy.

Prosimy o zachowanie danej instrukcji.

W przypadku problem, nie zrozumieniem lub innych trudności w procesie montażu bram, prosimy się zwrócić do służby technicznej pomocy („Służba technicznej pomocy”).

Zabrania się wykorzystywać i montować elementy i części zapasowe, których nie było dostarczonych przez producenta. Analogiczne elementy mogą być zamontowane tylko jeżeli było otrzymano zezwolenie na piśmie od producenta.

Uwaga! Zabrania się przebywanie dzieci na terytorium gdzie prowadzi się prace montażowe bramy. Oddzielne elementy mogą być trauma niebezpieczne.

Dla montażu napędu, prosimy, szczegółowo zapoznać się z instrukcją montażową napędu, uwzględniając wszystkie wskazówki uniemożliwiające uszkodzeniu bramy i własności.

Przed montażem bramy, proszę przekonać się w że światło bramy było przygotowane zgodnie z technicznymi żądaniami.

Światło bramy powinno być wolne od różnorodnych zbędnych elementów.

Ogólne warunki montażu

Żądania grupie montażowej.

Montaż bramy może być wykonany jedną osobą. Uwzględniając to, producent rekomenduje przeprowadzić montaż grupą pracowników składających się z dwóch osób, z którego jedna osoba powinna posiadać certyfikat na przeprowadzenia prac związanych z pracami pod napięciem.

Uśredniony montażowy czas wynosi 2 godziny.

Przed przystąpieniem do montażu, przekonajcie się że posiadacie wszystkie narzędzia ukazane na str. 21.

Odpowiedzialność za wykonanie montażu.

W związku z tym, że producent nie ma możliwości kontroli procesu montażu, za wszystkie możliwe ryzyka ponosi montażysta, łącznie z łączeniami do budynku.

We wszystkich przypadkach producent bram nie ponosi odpowiedzialności za finansowe straty, zepsucie własności i innych ryzykach które mogą pojawić się w procesie montażu.

Naznaczenie

Brama powinna przesuwać się bez dodatkowych sił.

Brama powinna być wyważona.

Zamykanie i otwieranie bramy bez wykorzystania napędu zezwala się z wykorzystaniem klamki. Uwaga! Nigdy nie umieszczać palce między panele nie z zewnątrz i wewnątrz.

Blokada bramy dopuszcza się tylko za pomocą specjalnego rygla lub mechanicznego zamka.

Elementy ruchome bramy powinny być posmarowane.

Nie dopuszczać dzieci do strefy pracy bramy.

Nie rozmieszczać światła bramy elementów przegród, a także na drodze przesuwania się bramy.

Techniczne problemy

W przypadku problem z urządzeniem, proszę zwrócić się do służby technicznej pomocy.

Służba technicznej pomocy

Informacje o gorącej linii służby technicznej pomocy ukazano w umowie przy zakupie urządzenia, którą Wy otrzymaliście od Waszegodilera.

Proszę zwrócić uwagę na to, że producent pozostawia za sobą prawo wnosić zmiany konstrukcyjne nie informując zamawiającego.

Dziękujemy za kupno naszych sekcyjnych bram.

SYMBOLE



- door element



- fastening element



- unpack



- incorrect installation



- correct installation



- apply force



- note



- set level



- dismantling

OPAKOWANIE + NIEZBĘDNE NARZĘDZIA

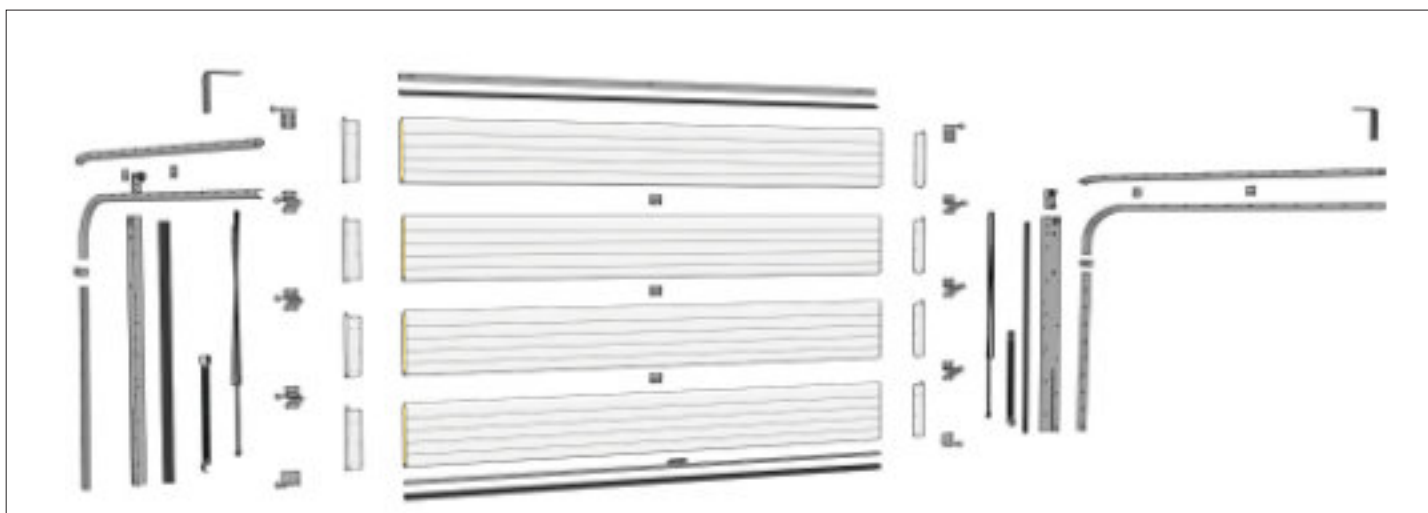
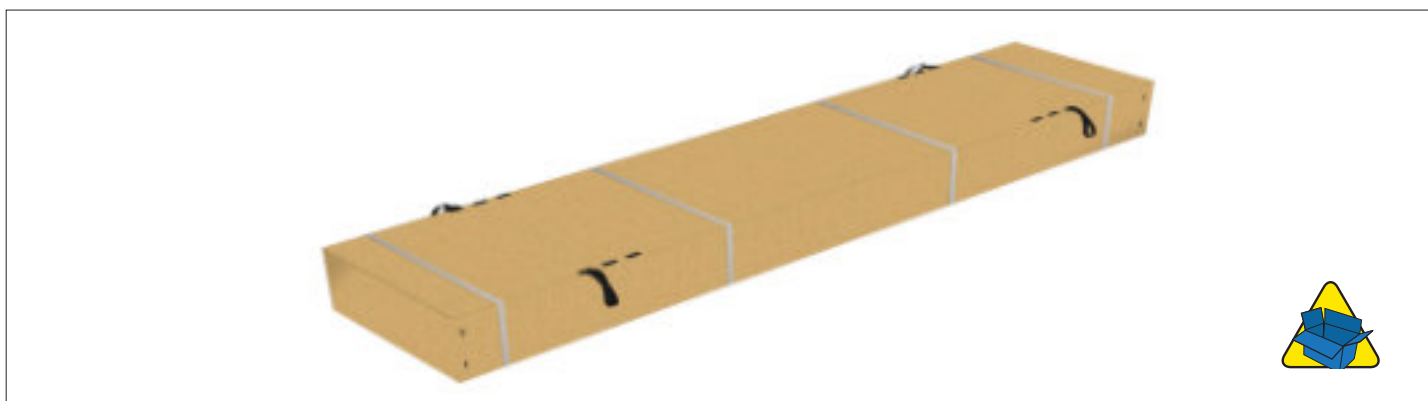

1,5 m



5 m



S10



T40



S10



S13



10 mm



KOMPONENTY

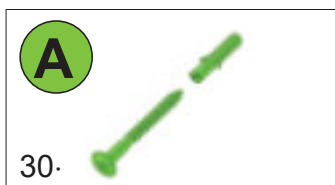
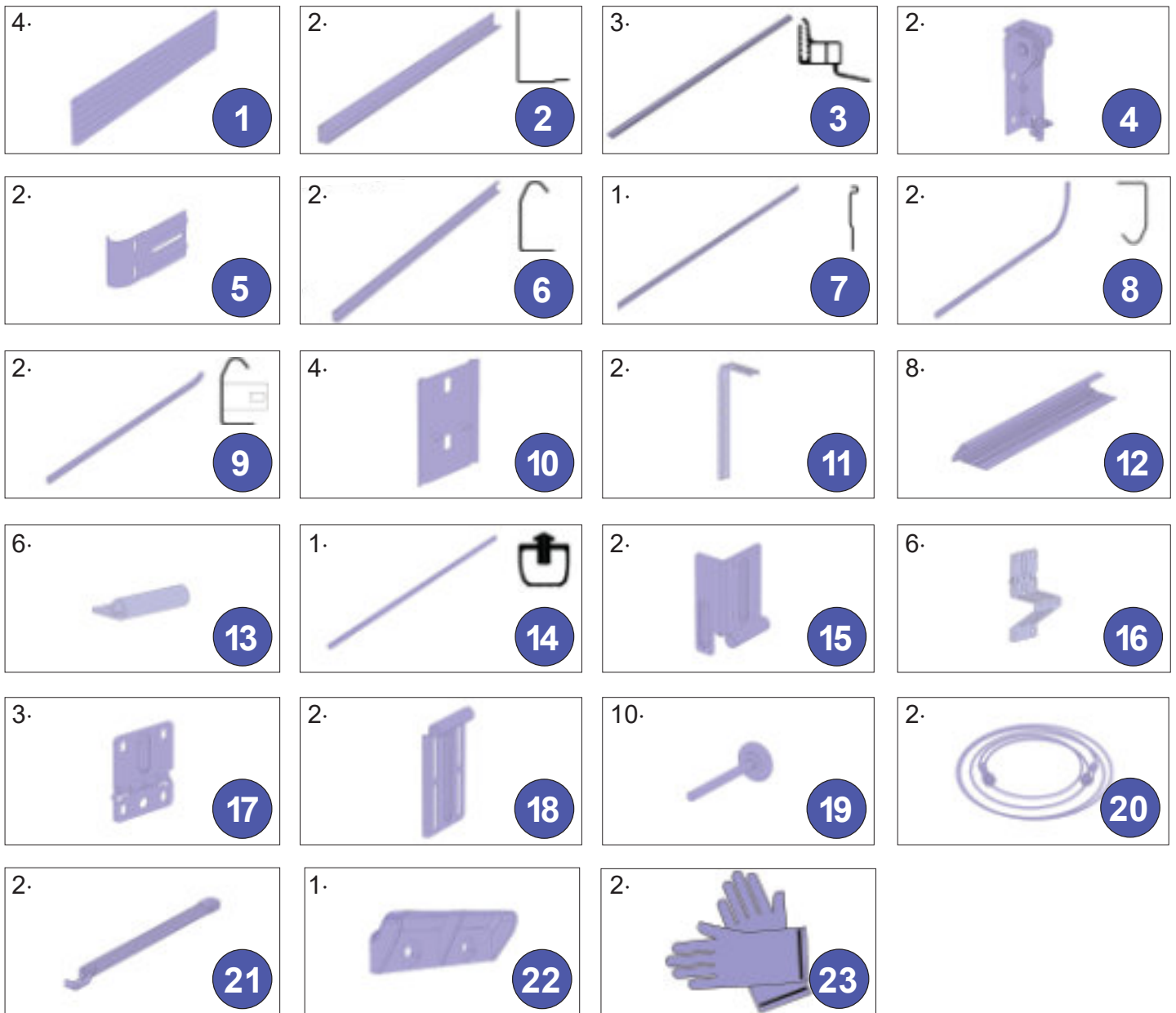

8 · 70 mm

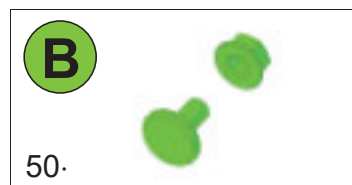

M 6 · 10 mm

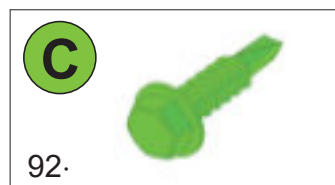

6,3 · 25 mm

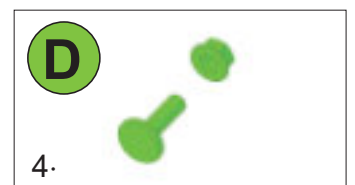

M 6 · 16 mm

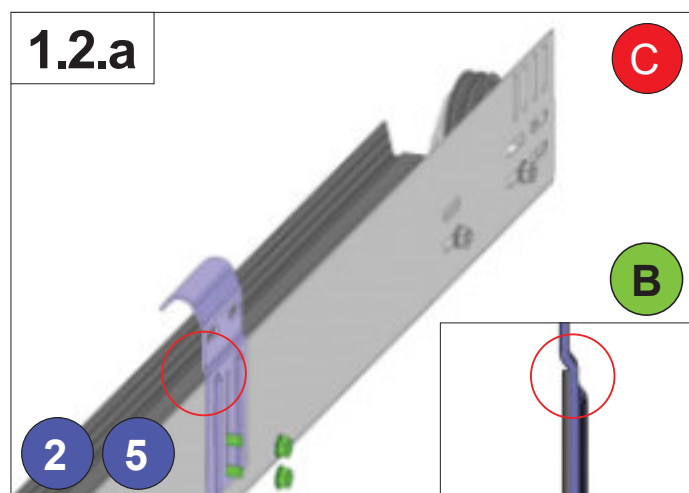
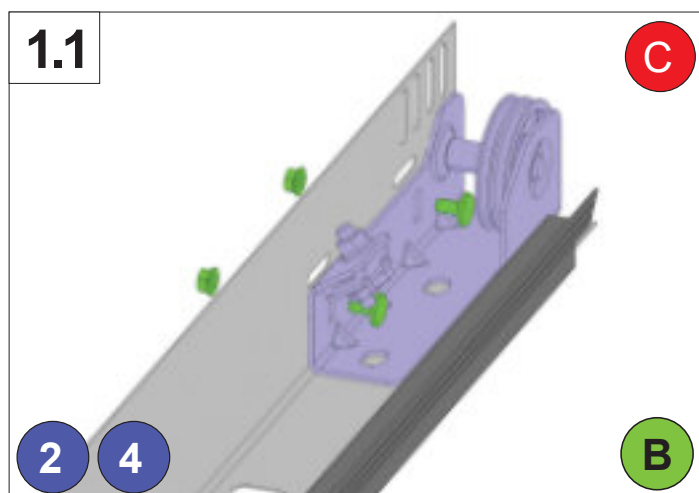
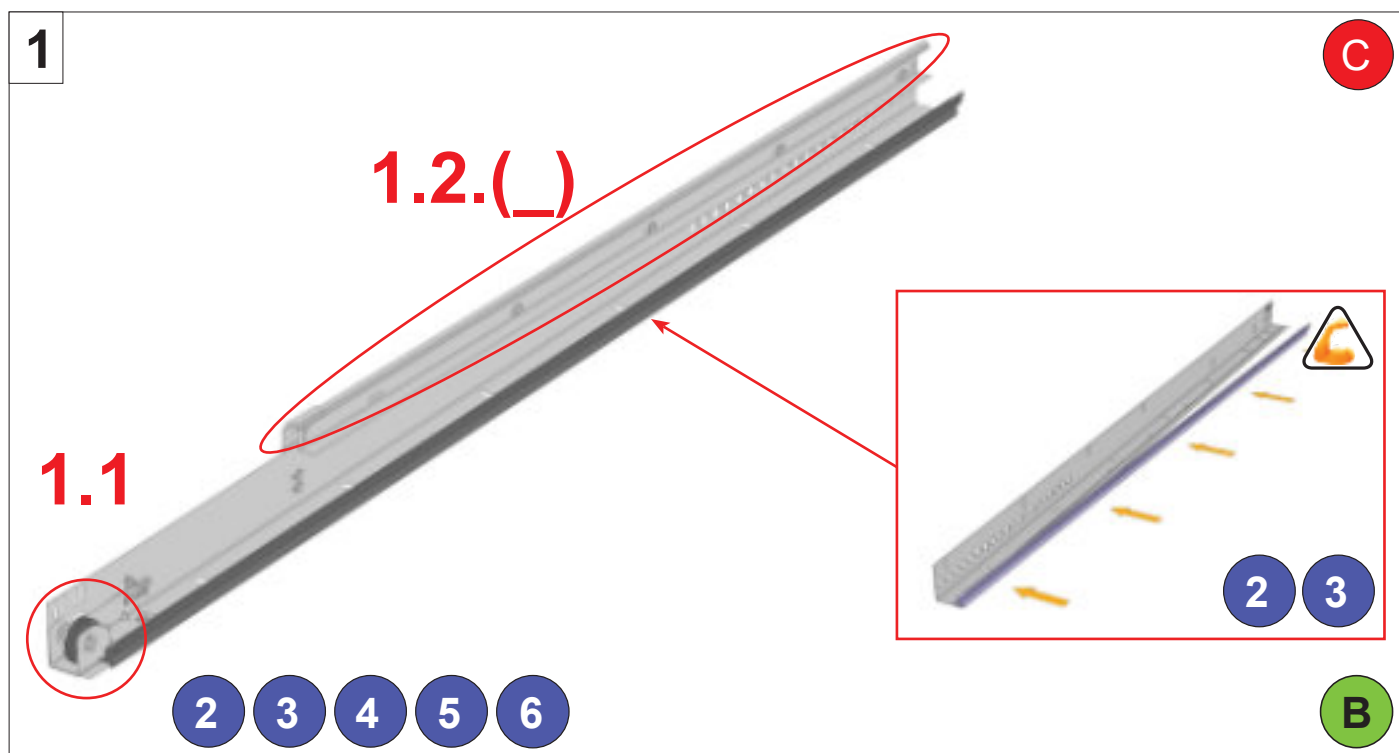
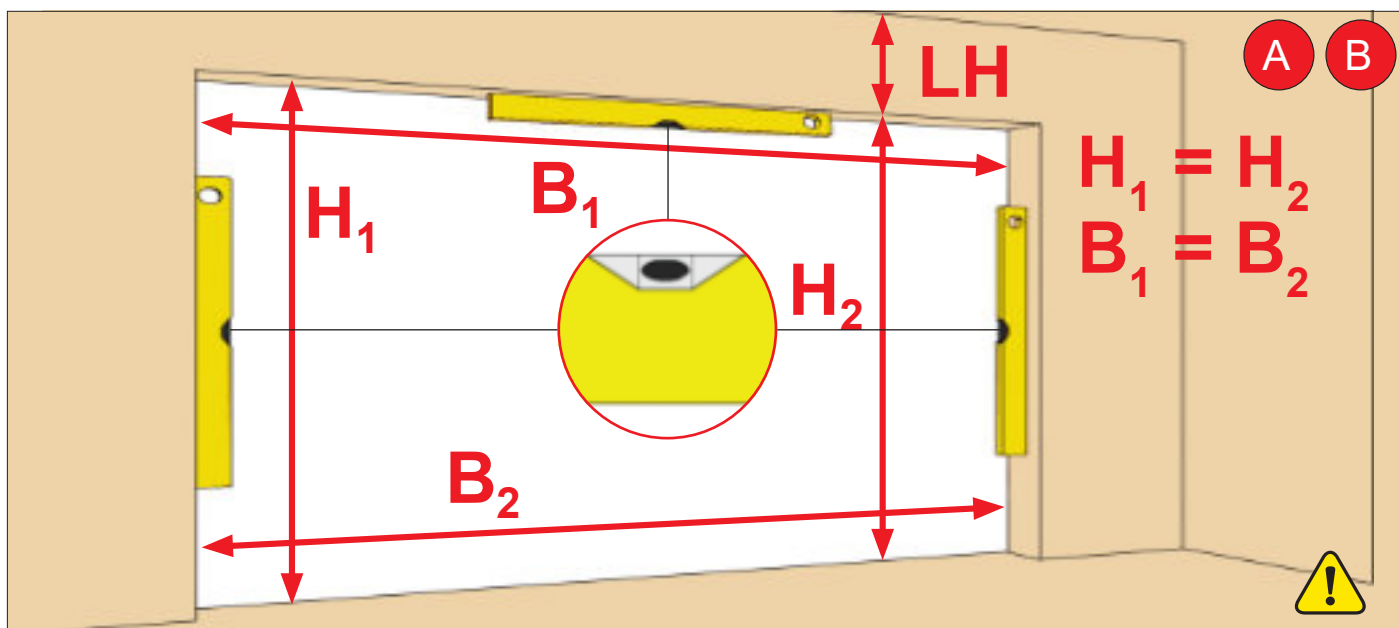

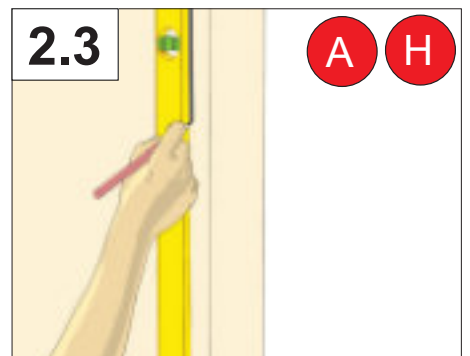
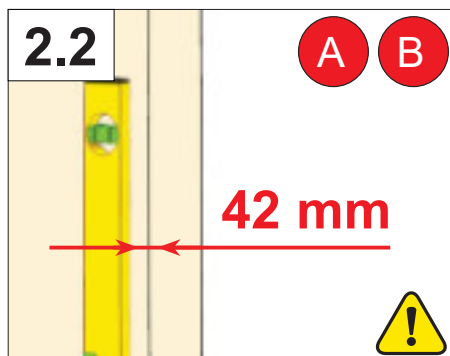
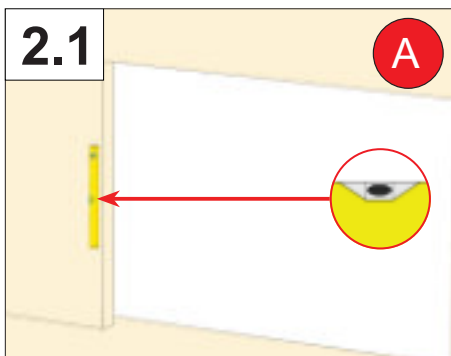
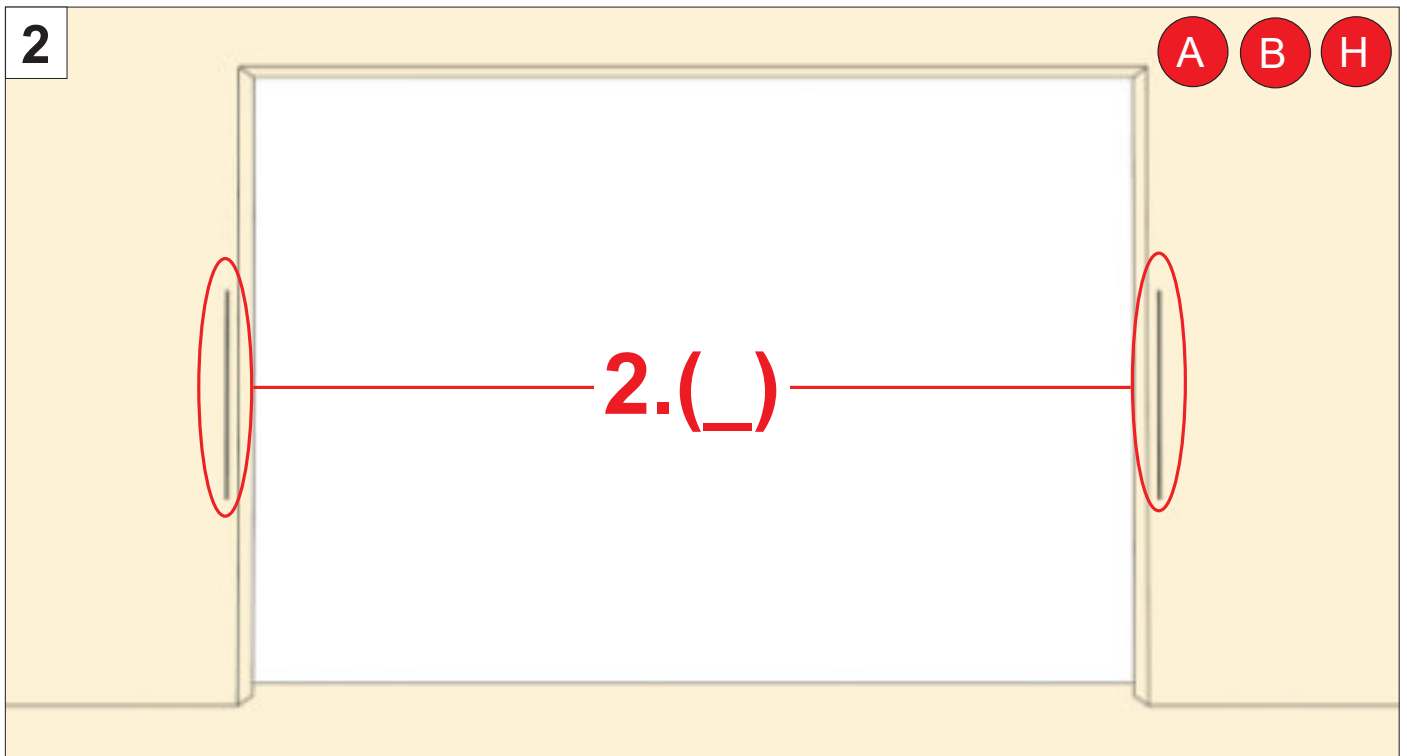
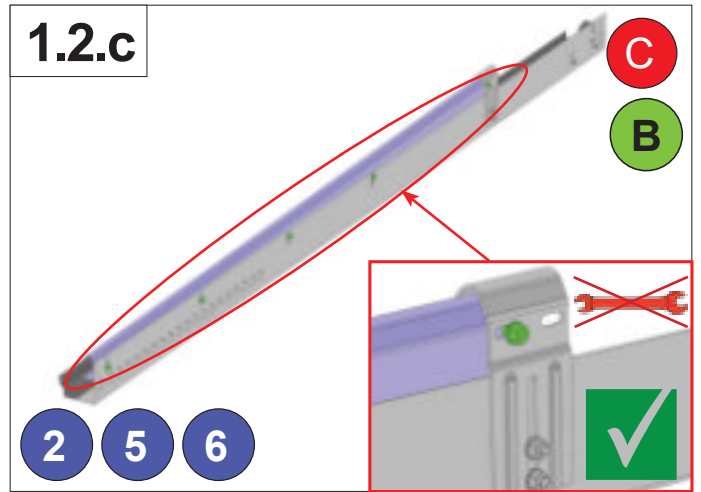
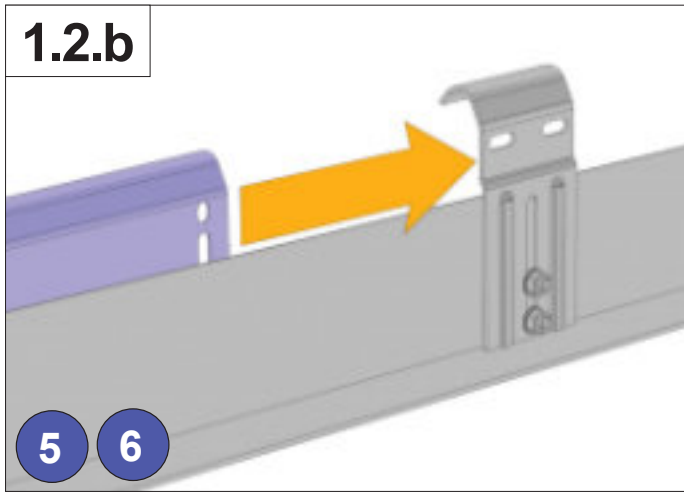

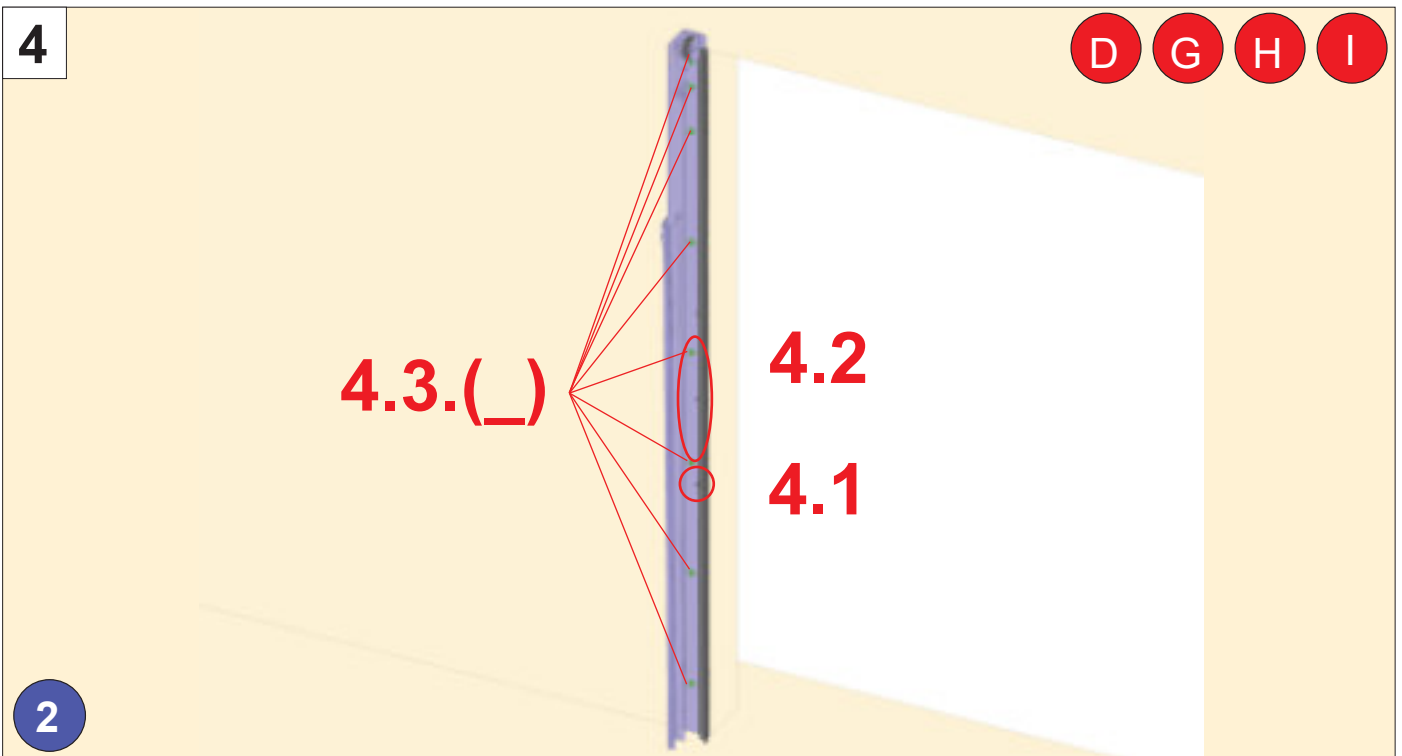
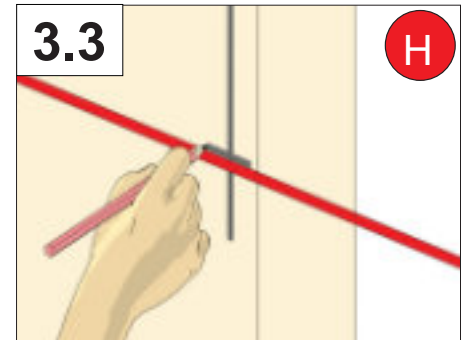
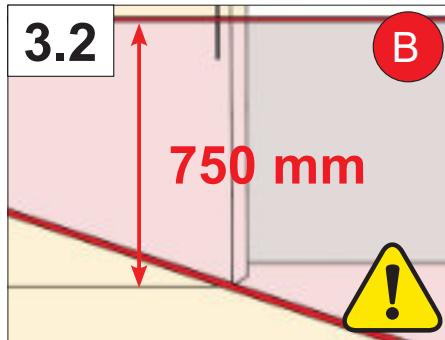
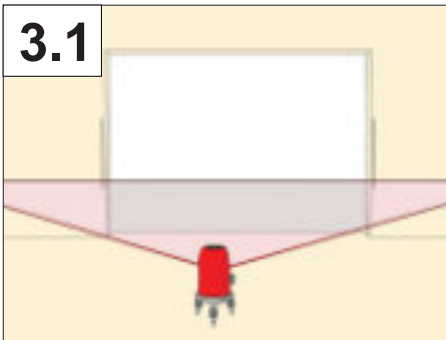
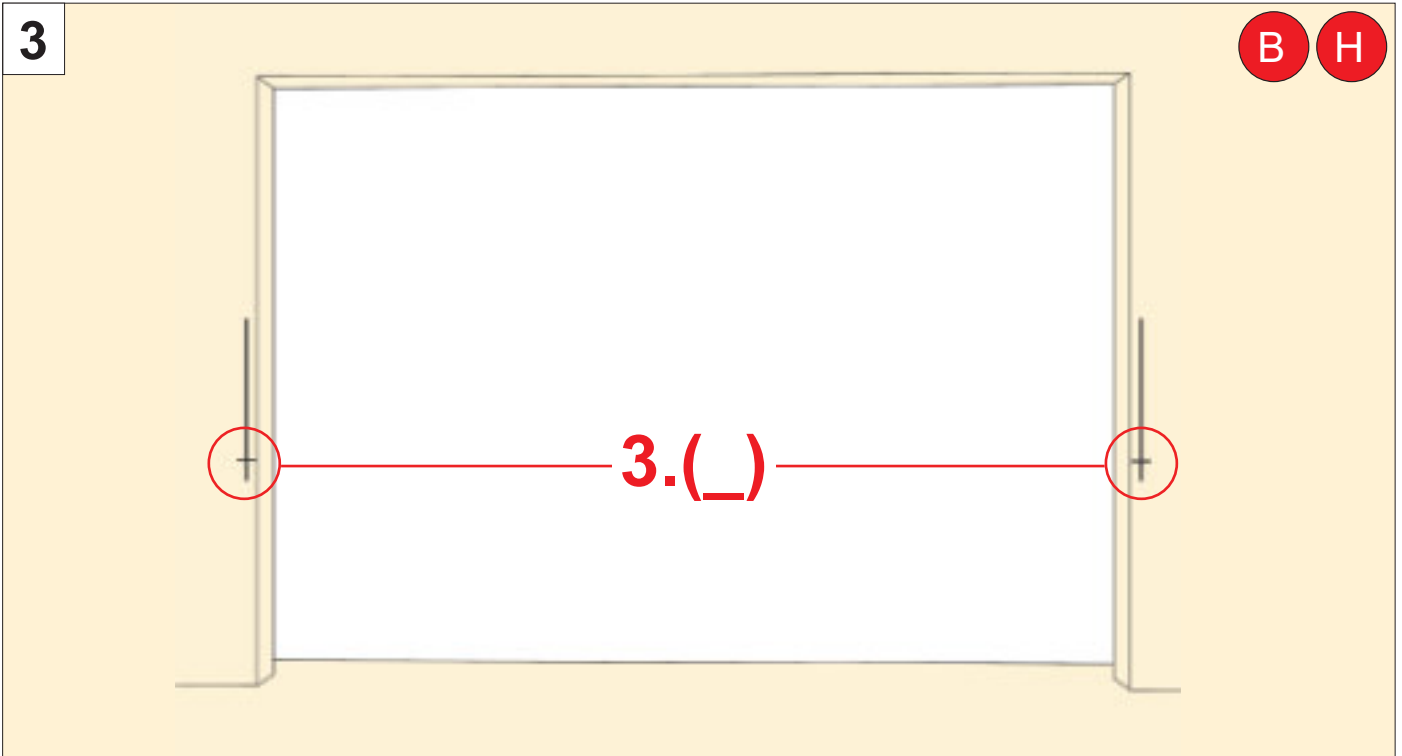

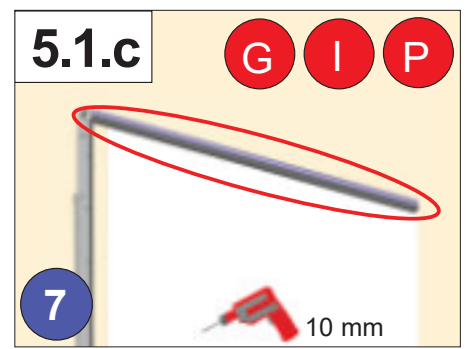
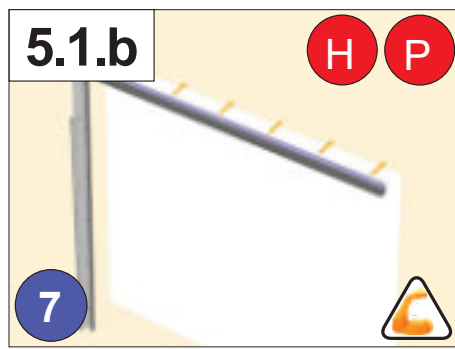
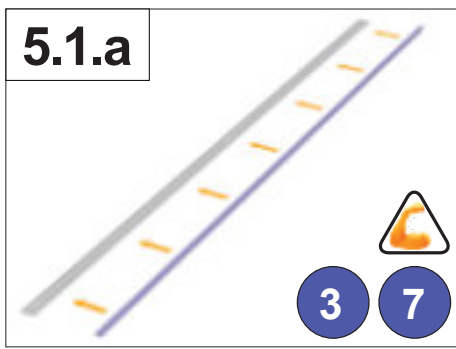
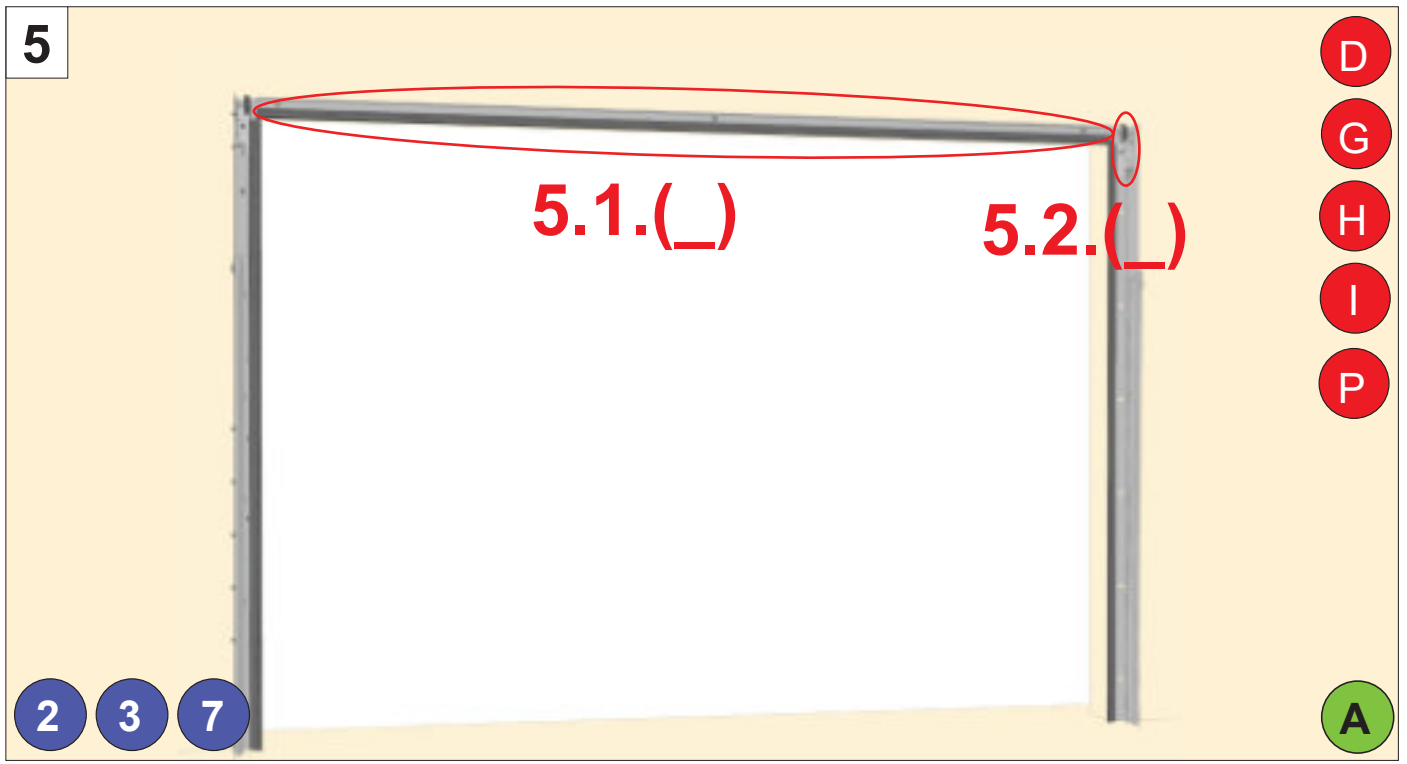
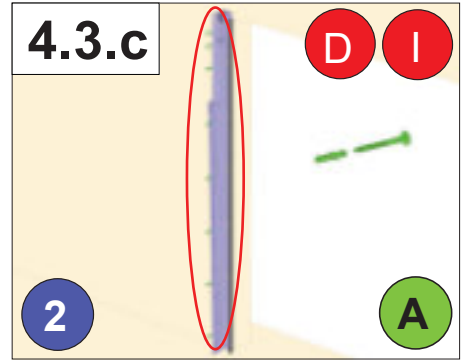
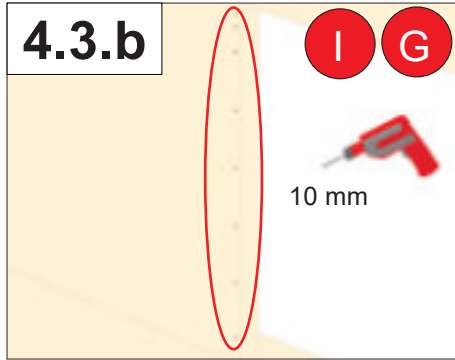
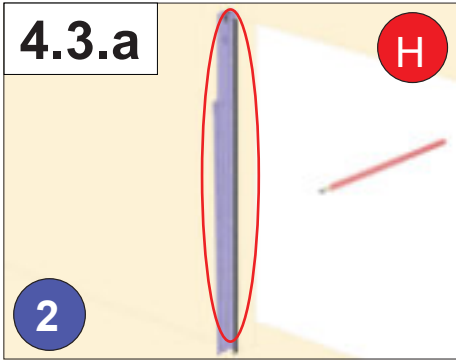
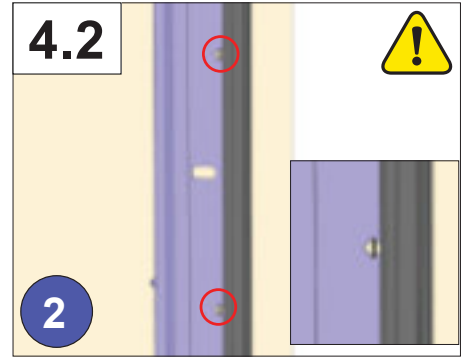
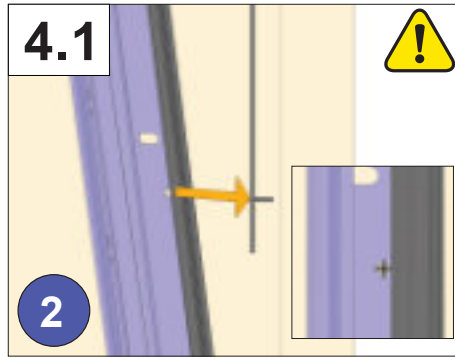
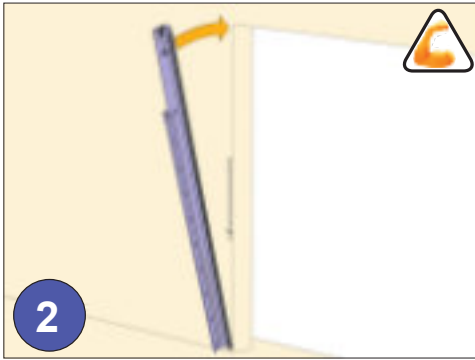

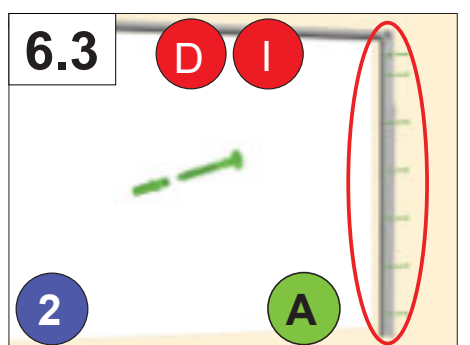
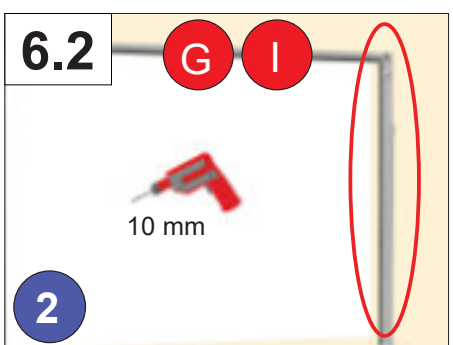
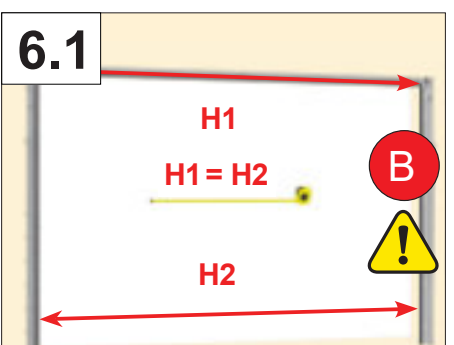
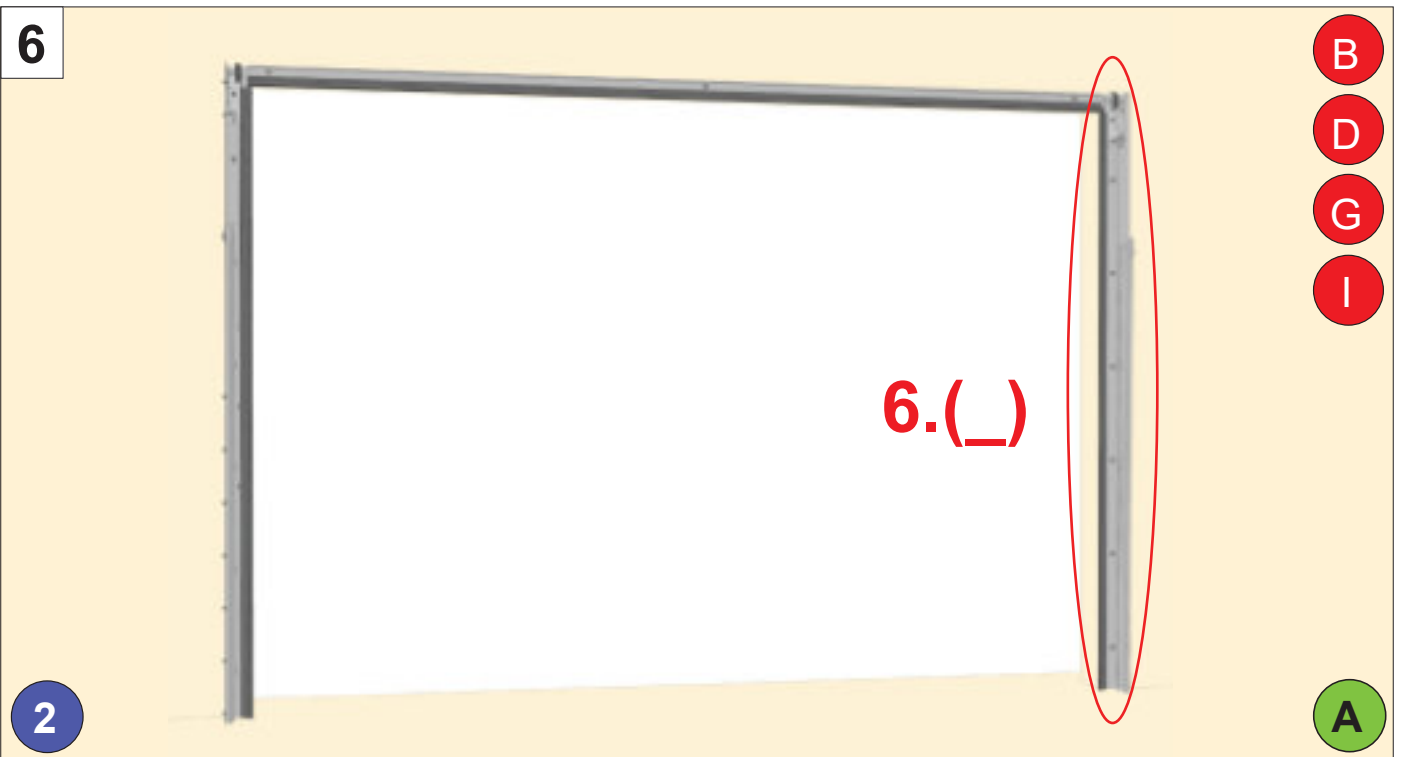
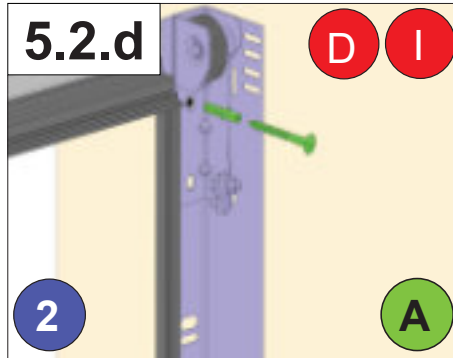
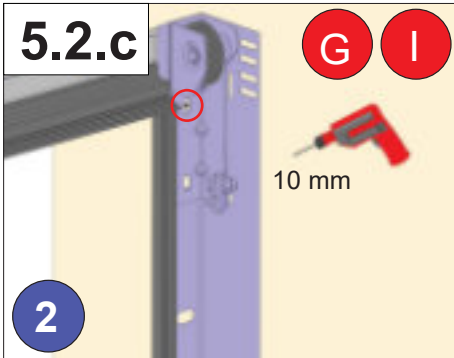
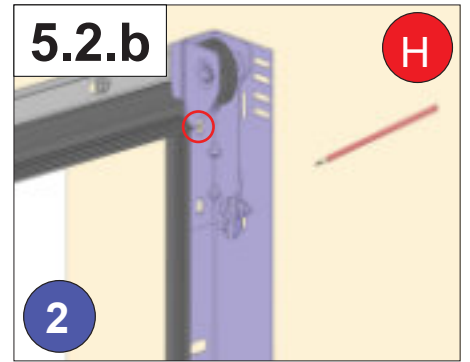
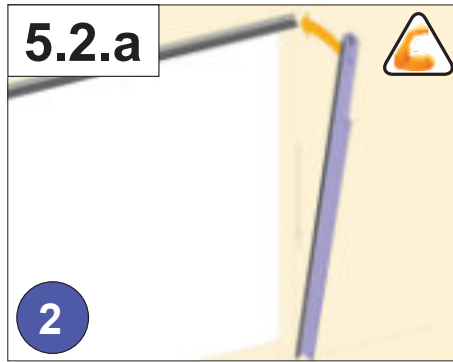
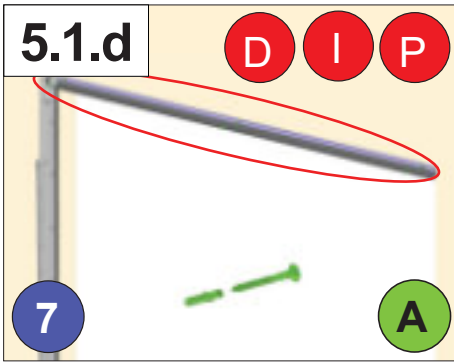

7

7.1.()



7.1.()

- A
- C
- I
- M
- O
- P

7.1.()



7.1.()

7.1.()



7.1.()

7.1.()



7.1.()

7.3.()

7.3.()

7.2.

- 1
- 12
- 13
- 14
- 15
- 19
- 20

C

7.1.a

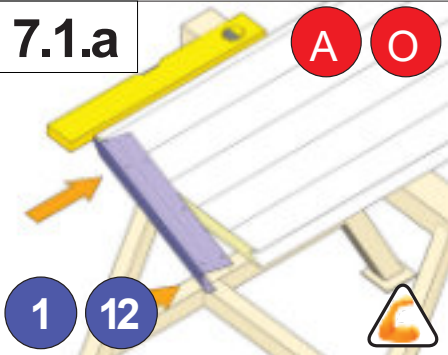

- A
- O

- 1
- 12



7.1.b

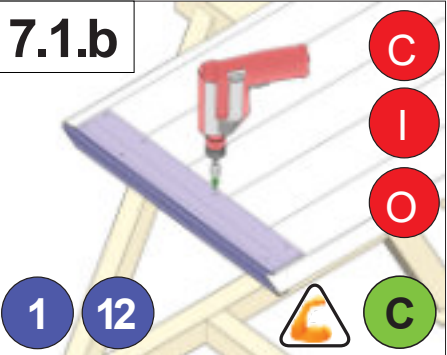

- C
- I
- O

- 1
- 12



C

7.3.a

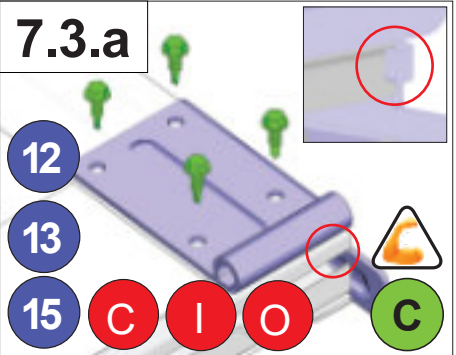

- 12
- 13
- 15
- C
- I
- O



7.2.

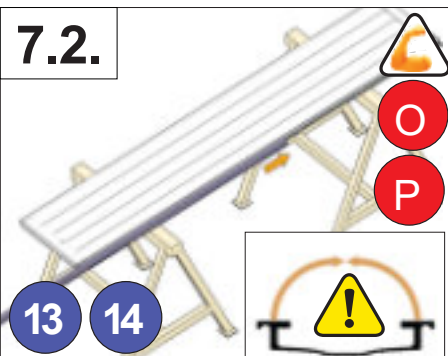

- O
- P

- 13
- 14



7.3.b

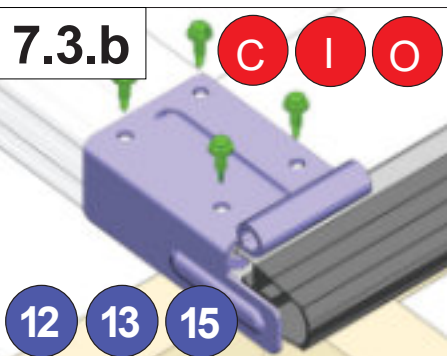

- C
- I
- O

- 12
- 13
- 15

7.3.c

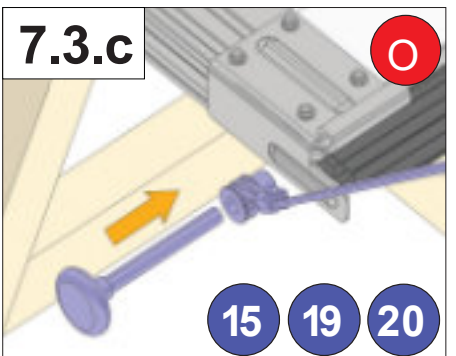

- O

- 15
- 19
- 20

8

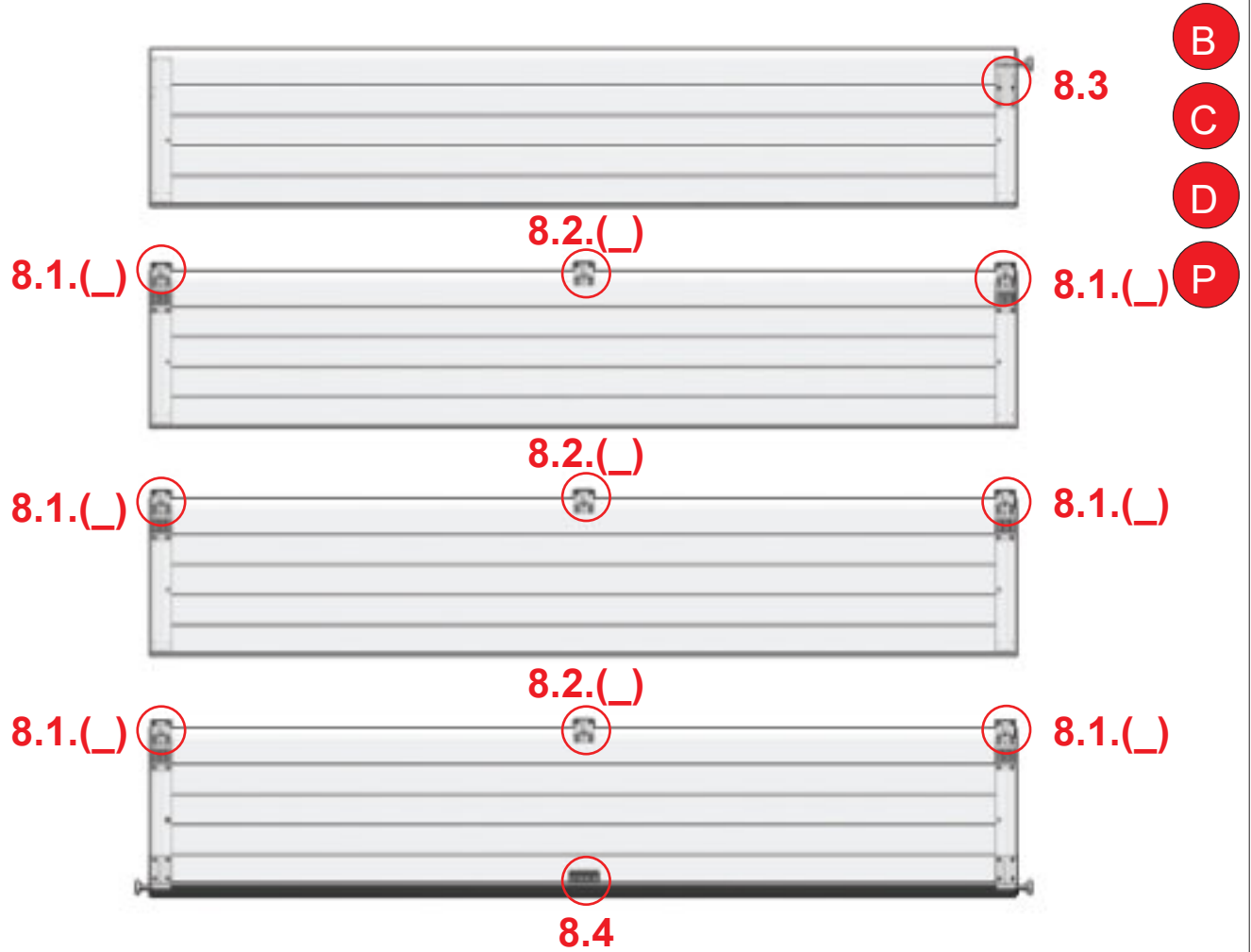

- 1
- 16
- 17
- 18
- 19
- 22

C

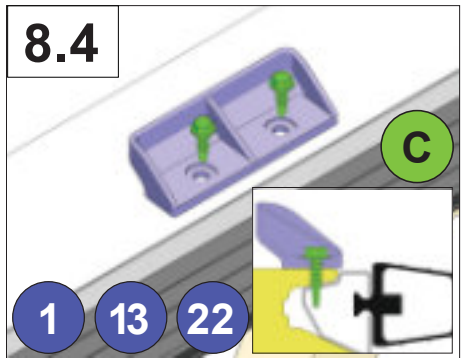
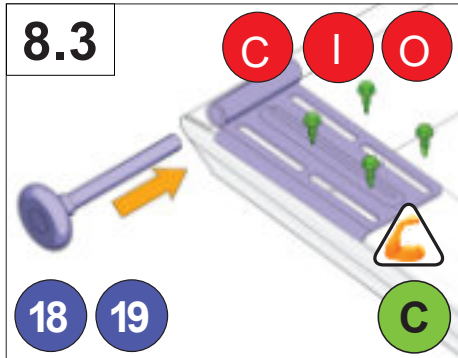
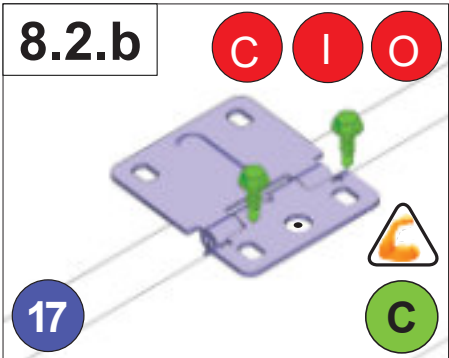
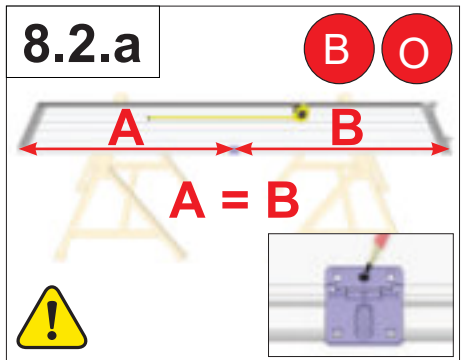
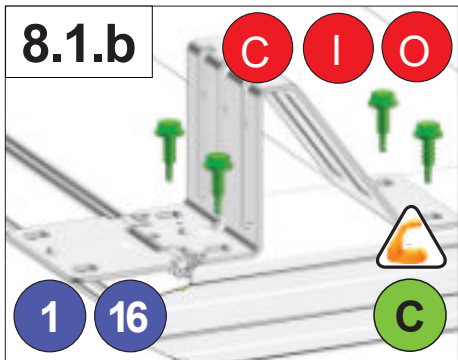
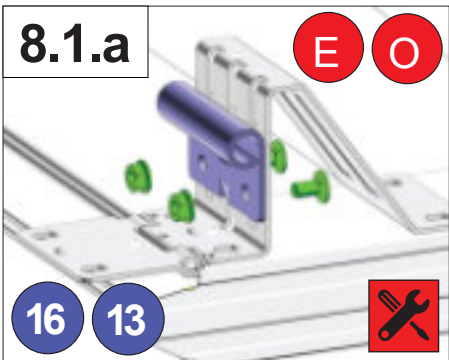

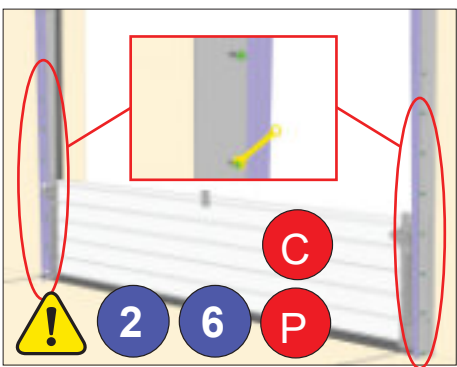
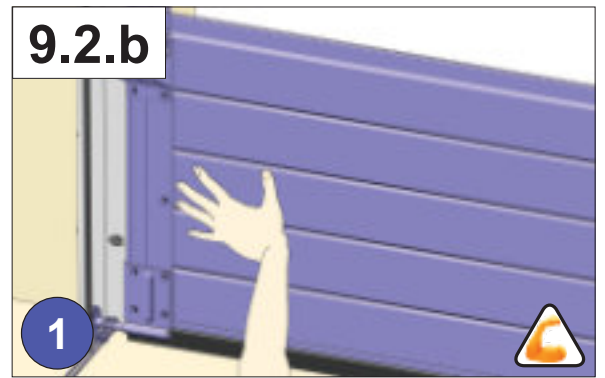
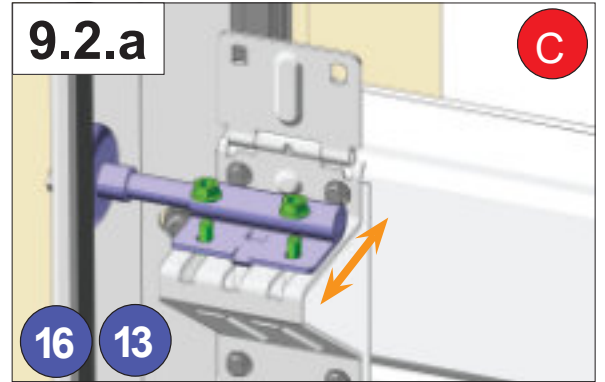
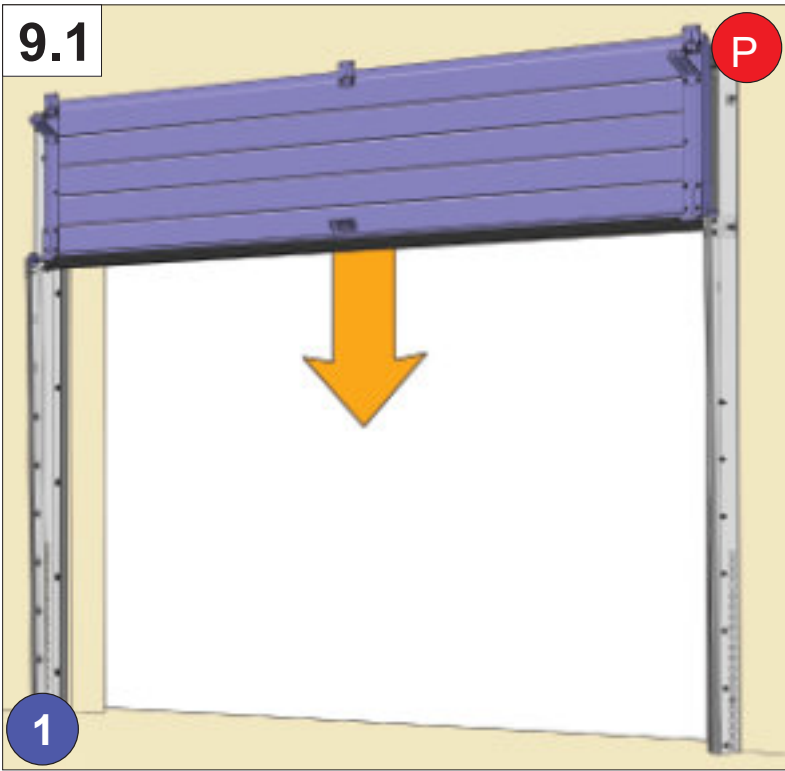
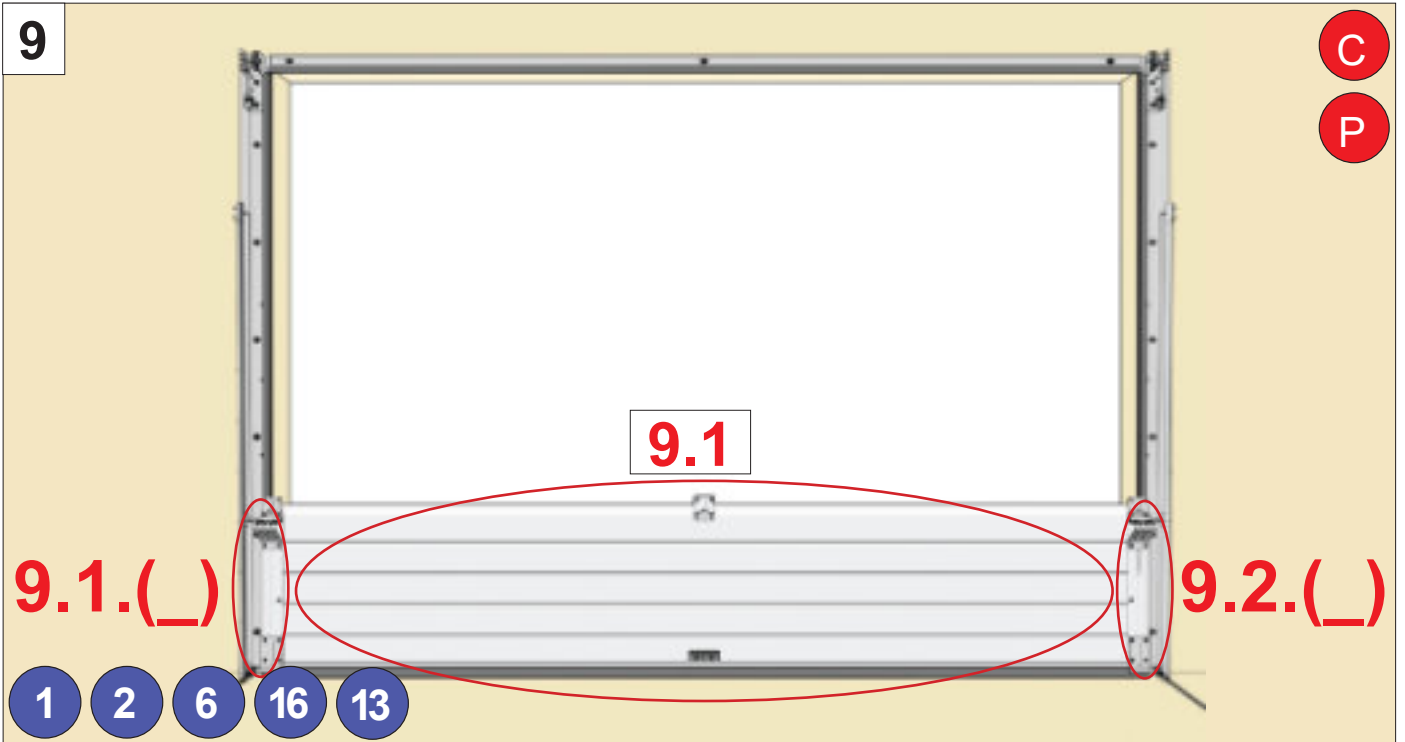

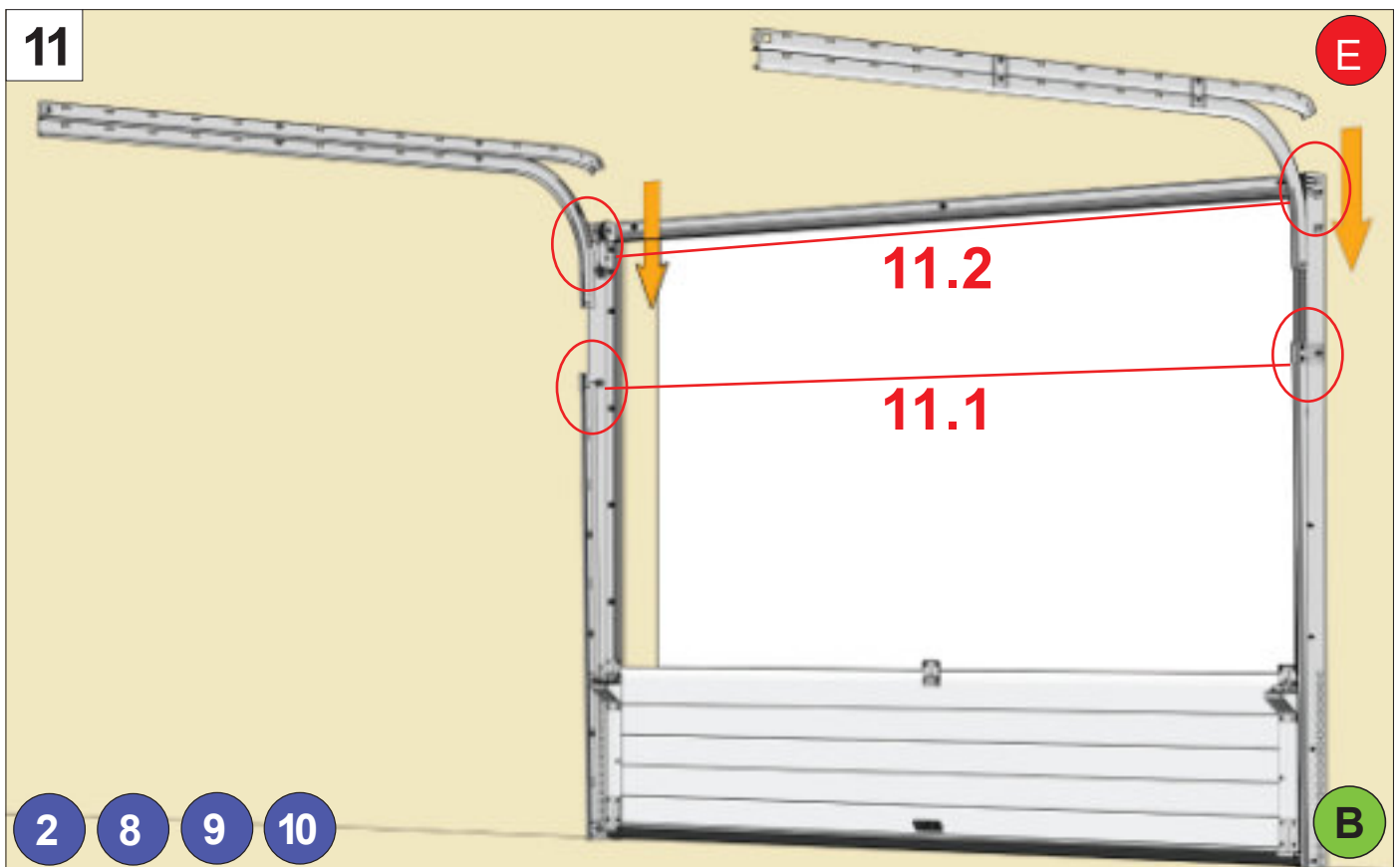
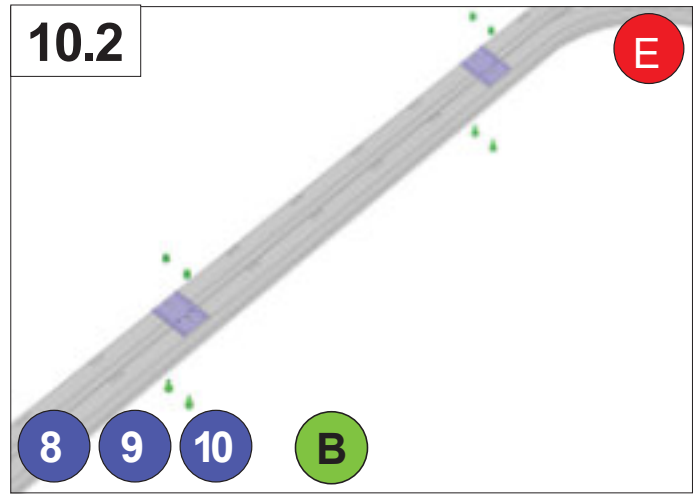
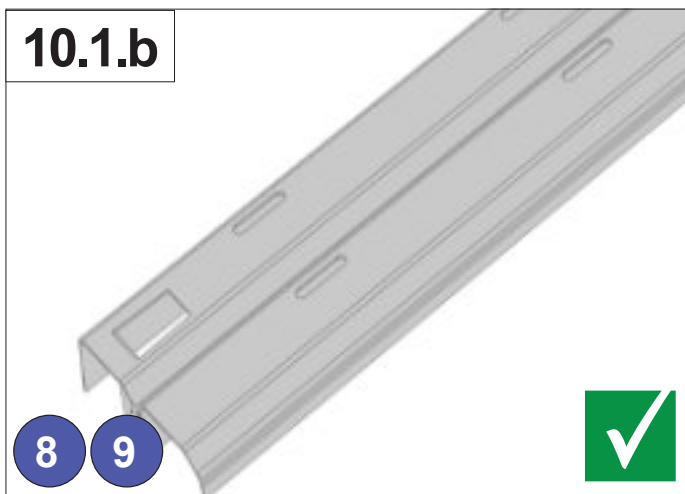
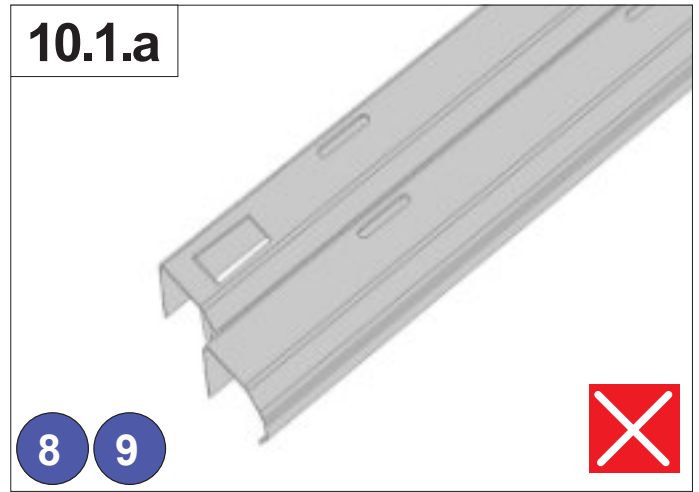
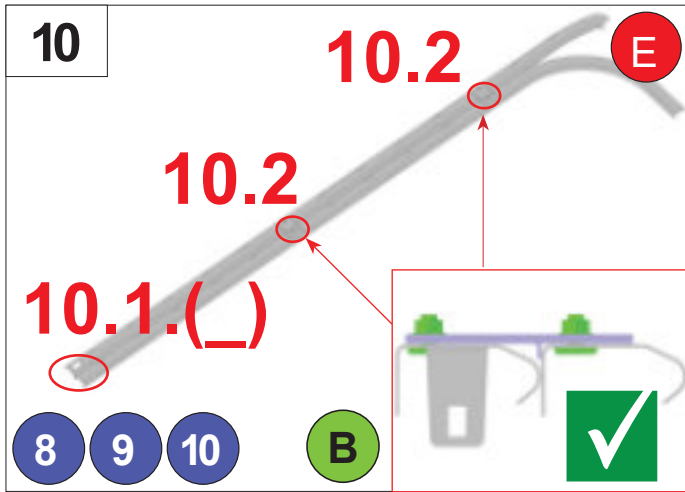

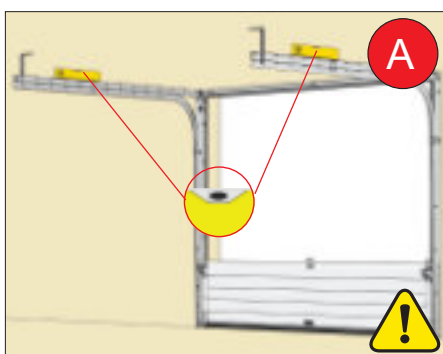
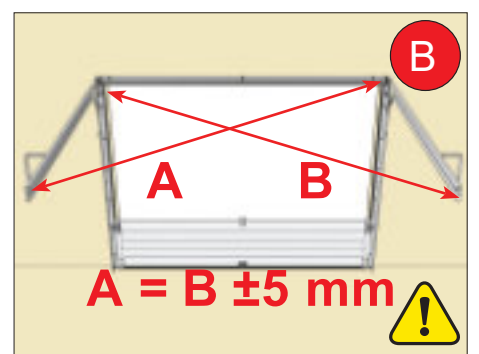
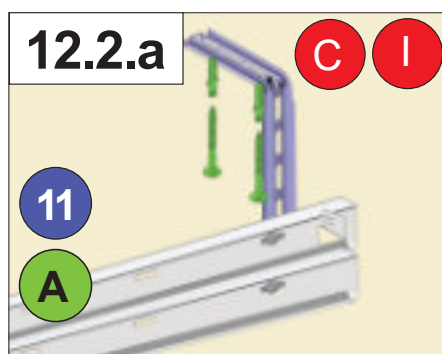
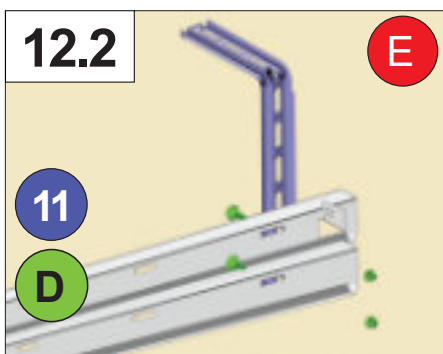
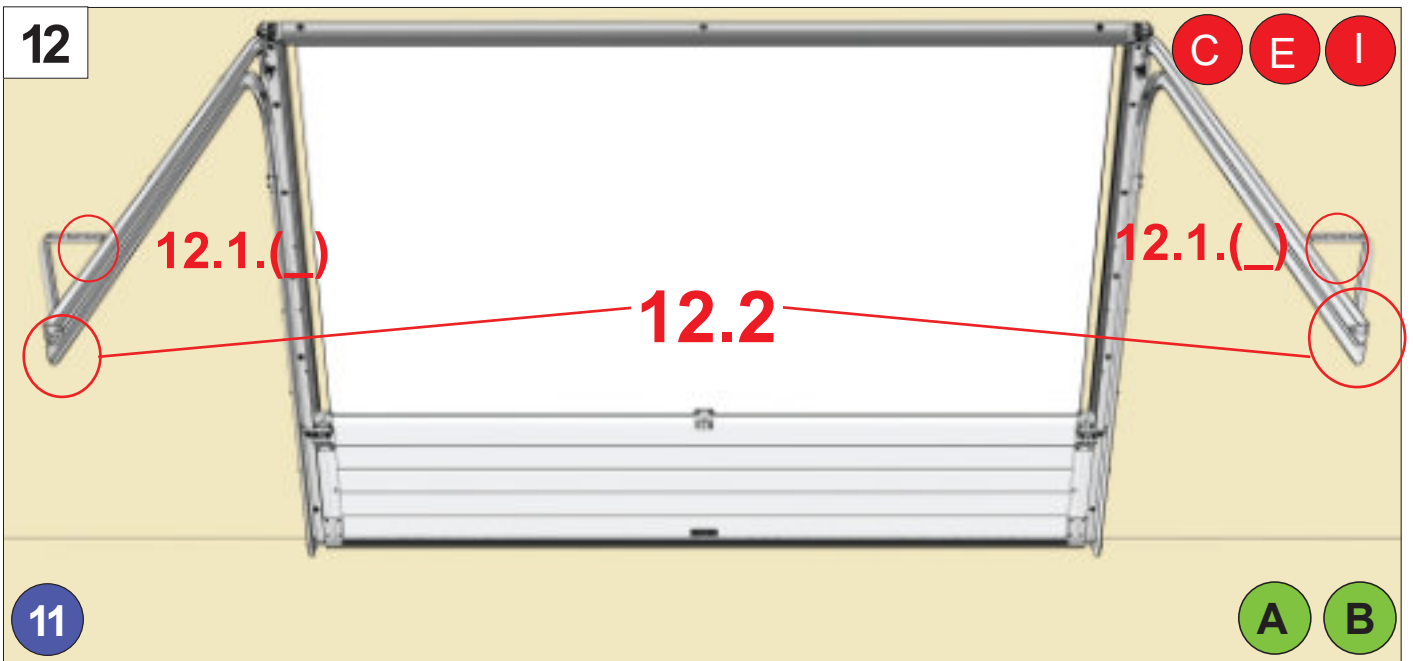
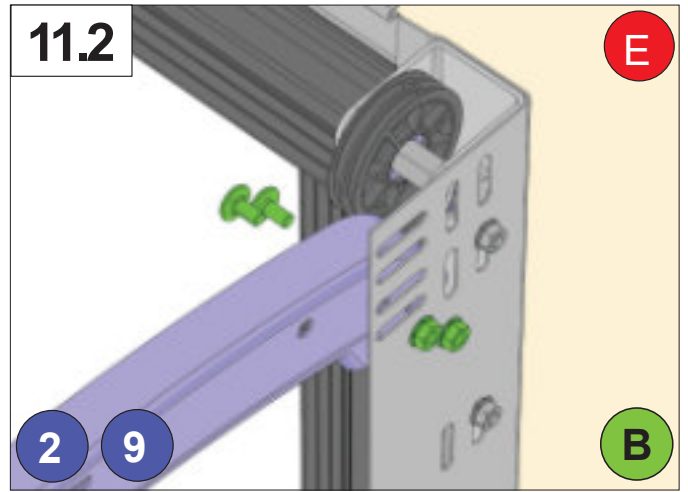
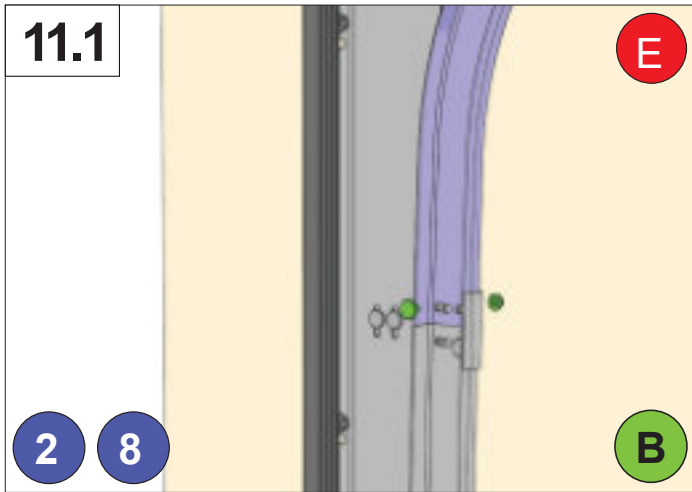

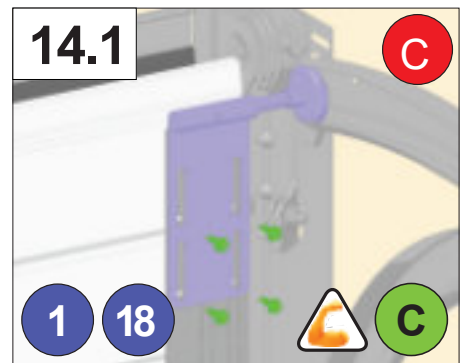
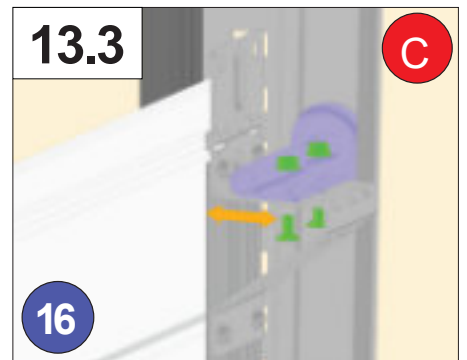
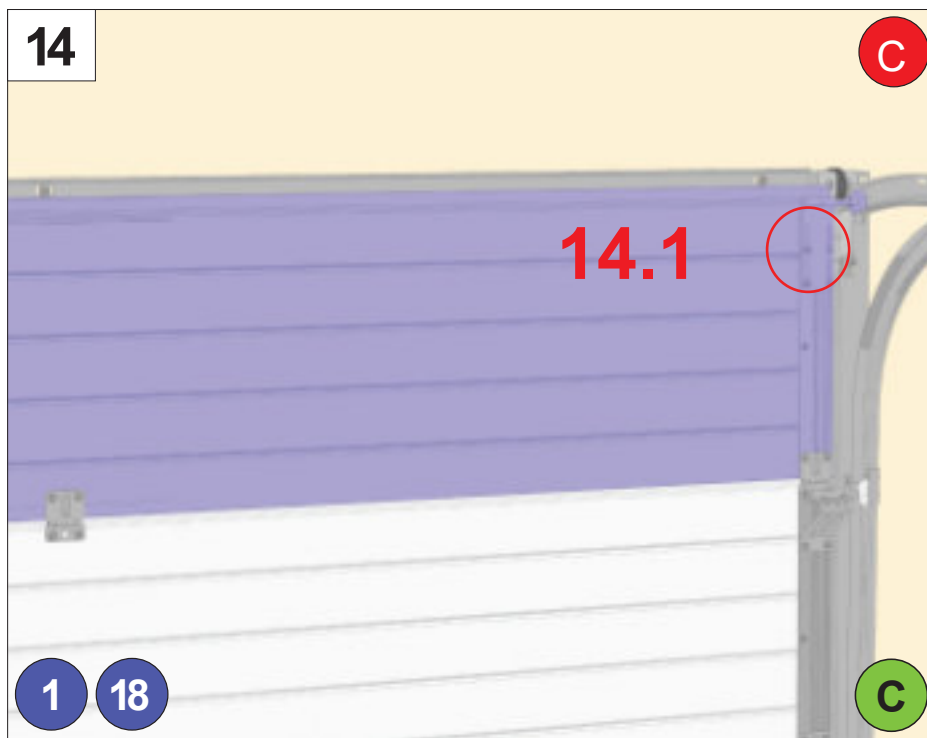
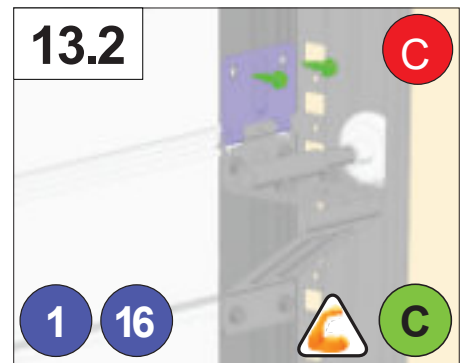
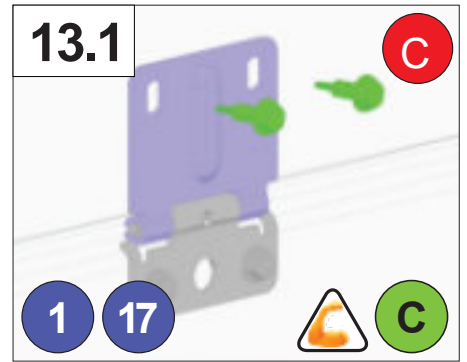
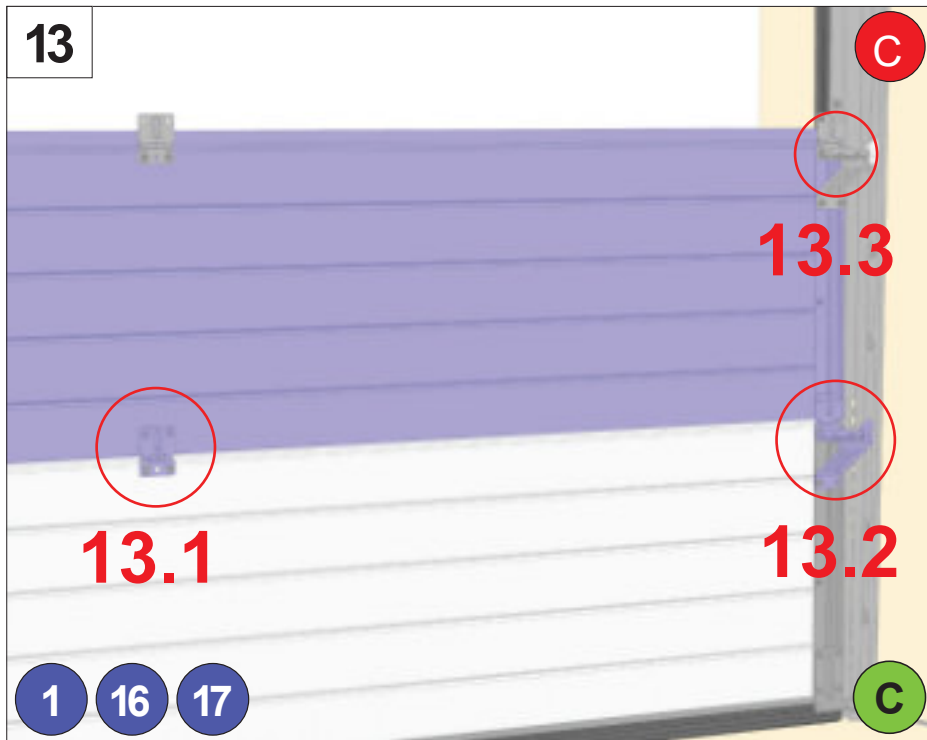

12

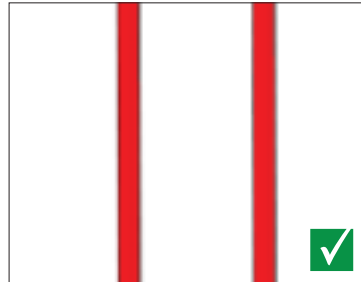
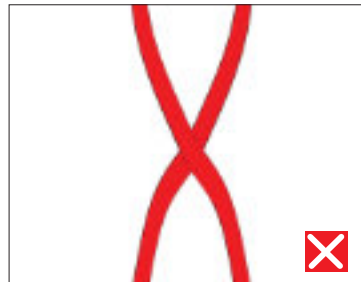
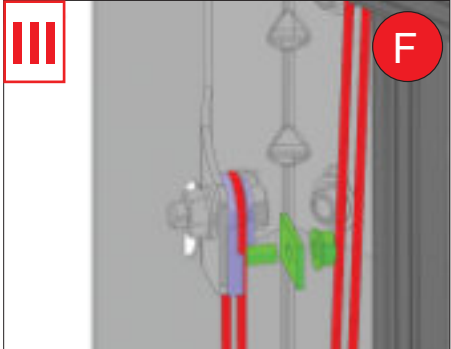
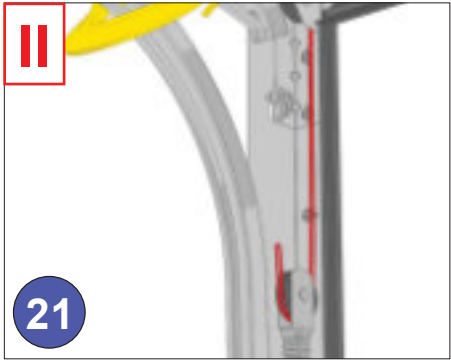
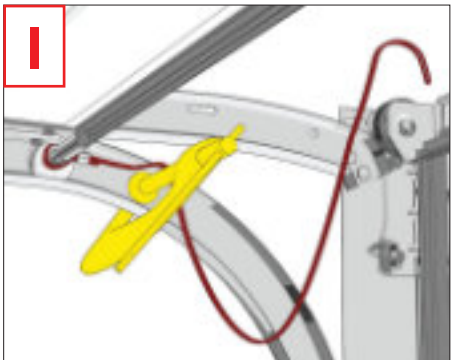
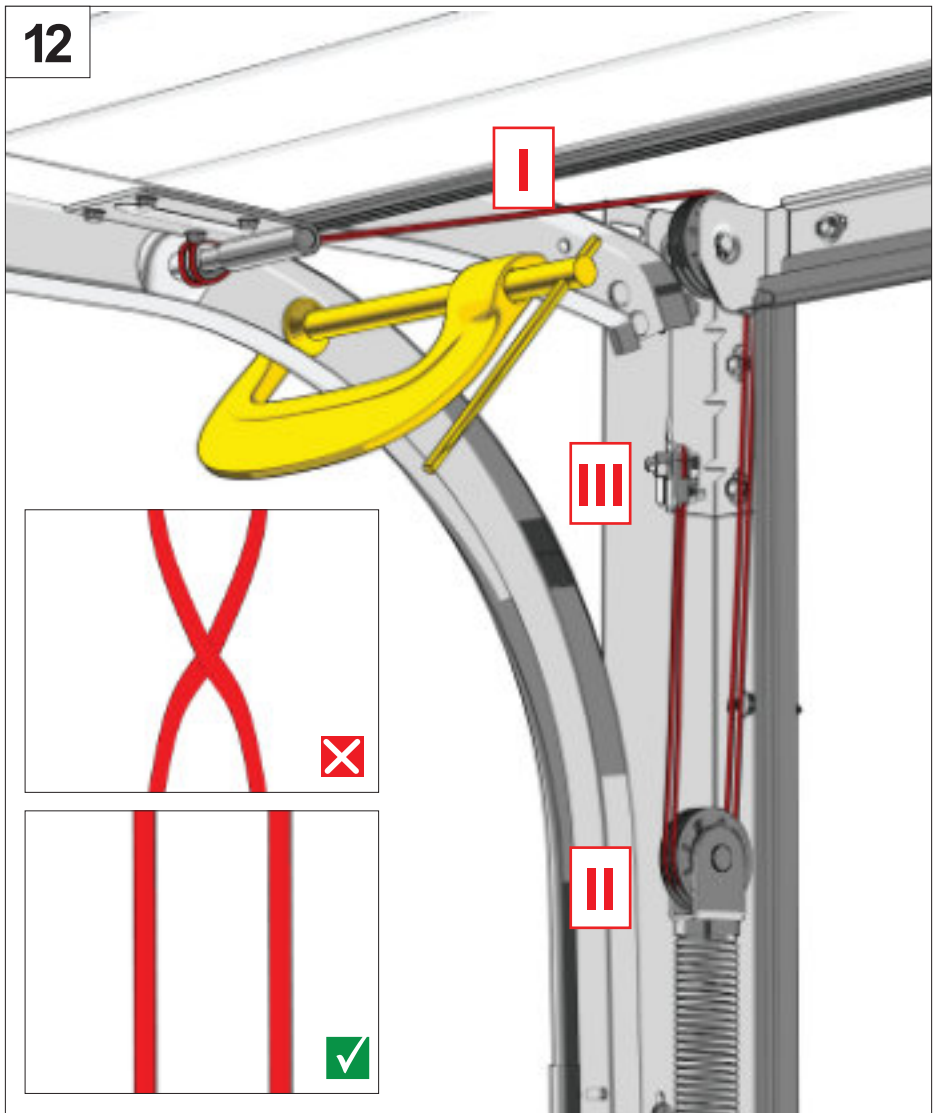

21

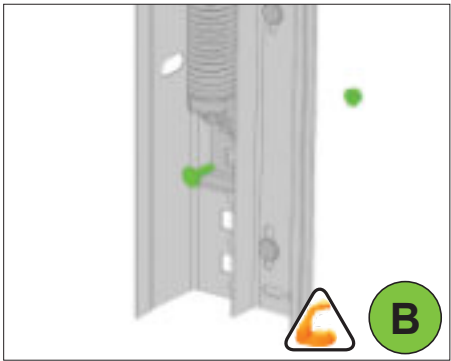
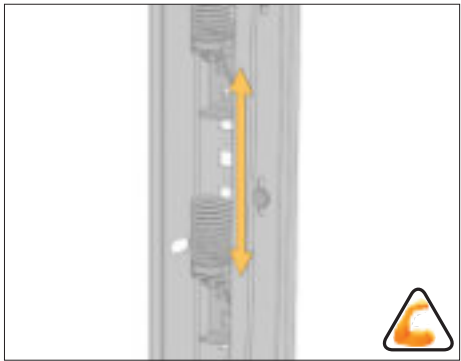
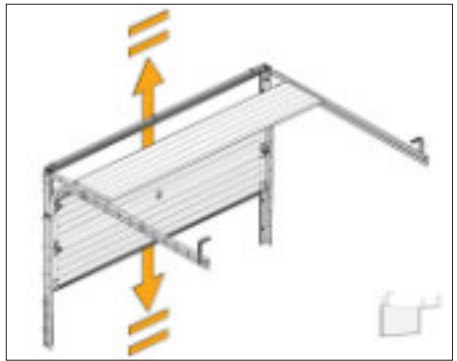



A series of horizontal dotted lines for writing, spaced evenly down the page.

